



Chemical Design Corporation

Air Driven Tools Care and Use

- The QWIK SPRAY 7500 is a precision crafted unit, which will last for a long time if properly maintained.
- Clean the tool carefully after using. Take care not to allow material to harden on parts of the tools as it makes it very difficult to perform routine maintenance.
- If solvent is used for cleaning, take care not to immerse the handle and drive cylinder. Solvents destroy the internal seals and the air regulator.
- Do not use the tool if the front carriage is loose – tighten the screws first.
- If the tool loses drive power, the first area to look for failure is the pressure regulator.
- If the drive rods become difficult to return, the problem may be the rubber dump valve diaphragm located at the back of the air cylinder. Remove the air regulator and clean the diaphragm.
- The air hose from the trigger to the air regulator can be removed by pressing in on the silver ring that the hose sticks into and pull the hose out. It works on the same principle as the Chinese Finger Trap.
- For further service information, please contact our service department at 1-800-578-8555.

Corporate Office: 906 H.D. Atha Rd. – Monroe, GA 30655 - (800) 578-8555 - (770) 207-4534 - Fax (770) 207-4535

This information and technical advice provided herein are believed to be reliable and accurate to the best knowledge of Chemical Design Corp., as based on tests and should serve only as a recommendation. As the manufacturer, Chemical Design Corp. makes no representations or warranties of any kind, expressed or implied, including but not limited to all implied warranties of merchantability or fitness for use or a particular purpose for the product. Chemical Design Corp. makes no representations or warranties as to the results of the use of the product and assumes no obligation or liability in connection therewith. Chemical Design Corp. is not liable for any incidental or consequential damages of any sort from use of this product. The information provided herein is subject to change at anytime without notice. Information changes may include, but are not limited to, commercial and technical changes, changes in pricing, physical characteristics and packaging.



Chemical Design Corporation

Air Driven Tools Operating Instructions

AIR CONNECTOR

Connect an airline to the applicator using the supplied quick connect or with a fitting that has a compatible screw thread.

LOAD CARTRIDGE PACK

- For two-part cartridges, join the two cartridges that are to be emptied using a static mixer and retaining nut.
- Ensure the plungers on the applicator are fully retracted.
- Drop the cartridges into the frame assembly by placing the rear of the cartridges over the plungers and then lowering the front of the cartridges into the front plate.

OPERATING THE TRIGGER

By pulling the trigger, a cushion of compressed air is built up inside the cylinder, which initiates the flow of coatings. On releasing the trigger, the coatings flow stops as the compressed air escapes through a quick exhaust valve.

ADJUSTING THE COATING FLOW

This is achieved with the pressure regulator at the rear or handle end of the applicator. To increase the flow of coating, turn the knob on the regulator in a clockwise direction. To decrease the flow, turn the knob in a counter-clockwise direction.

UNLOADING CARTRIDGE PACK

To enable the cartridges to be removed, the cartridge plungers must first be returned to the start position by pressing the return pusher back, pulling back on the rod or activating the automatic reverse air option as far as it will go. This is made easier by pointing the front of the applicator upwards.

CAUTION

- The line pressure connected to the applicator should not exceed 145 psi (10 bar).

- Always disconnect the airline prior to dismantling the applicator or changing the ratio-plates.
- It is recommended that protective eyeglasses be worn when using all pneumatic tools.

PERIODIC MAINTENANCE AND CLEANING INSTRUCTIONS

- To ensure trouble free operation, the applicator should be cleaned of all coating residue after use with the recommended solvent.
- Do not submerge, or “soak” the gun in any solvent.
- The recommended cleaning solvents for parts made of plastic or rubber are: Toluene (Toluol) and Xylene (Xylol).
- It is not recommended to “grease” or “oil” pneumatic guns with the exception of the trigger if it sticks.

Corporate Office: 906 H.D. Atha Rd-Monroe, GA 30655 - (800) 578-8555 - (770) 207-4534 - Fax (770) 207-4535

This information and technical advice provided herein are believed to be reliable and accurate to the best knowledge of Chemical Design Corp., as based on tests and should serve only as a recommendation. As the manufacturer, Chemical Design Corp. makes no representations or warranties of any kind, expressed or implied, including but not limited to all implied warranties of merchantability or fitness for use or a particular purpose for the product. Chemical Design Corp. makes no representations or warranties as to the results of the use of the product and assumes no obligation or liability in connection therewith. Chemical Design Corp. is not liable for any incidental or consequential damages of any sort from use of this product. The information provided herein is subject to change at anytime without notice. Information changes may include, but are not limited to, commercial and technical changes, changes in pricing, physical characteristics and packaging.



Chemical Design Corporation

Air Driven Tools

Operating Instructions

CARTRIDGE LOADING

Two Component Applicators with cartridge locators

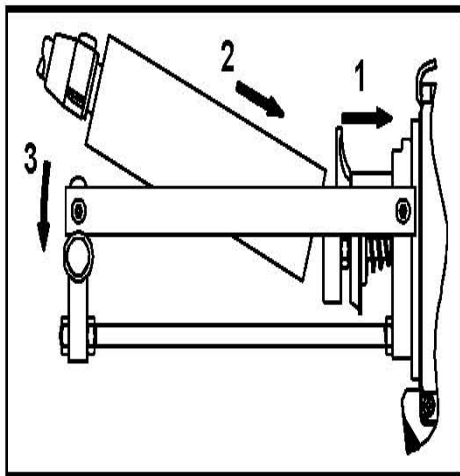

1. Ensure rods are fully retracted towards the barrel.
2. Locate rear of cartridge over plungers and onto cartridge locators.
3. Push back firmly until the front of the cartridge can be located into the frame assembly.
4. Check that the cartridge is correctly located before operating the trigger.

Corporate Office: 906 H.D. Atha RD – Monroe, GA 30655 - (800) 578-8555 - (770) 207-4534 - Fax (770) 207-4535

This information and technical advice provided herein are believed to be reliable and accurate to the best knowledge of Chemical Design Corp., as based on tests and should serve only as a recommendation. As the manufacturer, Chemical Design Corp. makes no representations or warranties of any kind, expressed or implied, including but not limited to all implied warranties of merchantability or fitness for use or a particular purpose for the product. Chemical Design Corp. makes no representations or warranties as to the results of the use of the product and assumes no obligation or liability in connection therewith. Chemical Design Corp. is not liable for any incidental or consequential damages of any sort from use of this product. The information provided herein is subject to change at anytime without notice. Information changes may include, but are not limited to, commercial and technical changes, changes in pricing, physical characteristics and packaging.



Chemical Design Corp.

PNEUMATIC TWO COMPONENT LIQUID COMPOSITES APPLICATORS OPERATING INSTRUCTIONS

SAFETY

This applicator is a quality product for the professional user; it is designed for high duty cycles over long operating periods. As compressed air is used as the power source, operator fatigue is minimal, but it must be remembered that compressed air can be dangerous when used incorrectly. The user should take time to read and understand these operating instructions fully.

ALWAYS

- USE PROTECTIVE EYE & EAR EQUIPMENT WHEN OPERATING.
- DISCONNECT THE AIR SUPPLY BEFORE STARTING ANY MAINTENANCE / CLEANING TASKS.

NEVER

- CONNECT THE APPLICATOR TO AN AIR SUPPLY WHICH CAN EXCEED 145 P.S.I (10 BAR)
- IMMERSE THE GUN IN SOLVENT.
- OPERATE THE GUN WITH LOOSE, BROKEN OR MISSING PARTS.
- CARRY THE GUN BY THE AIR PIPE.
- USE DAMAGED CARTRIDGES OR THE WRONG TYPE OF CARTRIDGE IN THE APPLICATOR.

CONNECTION

Check the supply pressure. For optimum performance the supply pressure must be greater than 100 P.S.I (6.8 bar) and less than 145 P.S.I. (10 bar) and a CFM of 8 - 10. The applicator will work at lower supply pressures, but flow rates could be reduced and may vary. Connect the applicator to a suitable compressed air source using the supplied fitting, or with a suitable fitting. All applicators are fitted with a male 1/4" BSP thread.

OPERATION / CONTROLS

A INTERNAL PRESSURE REGULATOR

The internal pressure regulator controls the liquid composites flow rate and ensures a stable flow of liquid composites is maintained. To increase the flow of liquid composites, turn the knob in a clockwise (+) direction. To decrease the flow, turn the knob in a counter clockwise (-) direction.

B TRIGGER

By pulling the trigger, a cushion of compressed air is built up inside the applicator, this initiates the flow of liquid composites. On releasing the trigger, the liquid composites flow ceases as the compressed air escapes rapidly by a quick exhaust valve at the rear of the gun.

C PLUNGER RETURN BUTTON (Where fitted)

Press and hold the plunger return button (C), then pull the trigger (B). This will pull back the plunger rods automatically ready for the next cartridge. If the applicator is not fitted with the air return button, manually pull back the plungers using the indicator knob (D).

D INDICATOR / RETURN KNOB

This gives a visual indication of how much material is remaining in the cartridge during use. For guns not fitted with air return, the return knob is used to manually pull the plungers back.

MAINTENANCE

DAILY: Wipe the applicator using the liquid composites manufacturers recommended solvent before it has time to set. Special care should be taken to make sure no residue is left on the rods.

WEEKLY: Check the plungers and all external bolts / screws are tight. Tighten if found to be loose.

MONTHLY: Lubrication of internal pistons and seals: Place 3 drops of oil on the air inlet at the bottom of the butt. Recouple the air line and when next operated the compressed air will blow the oil into the workings of the gun.

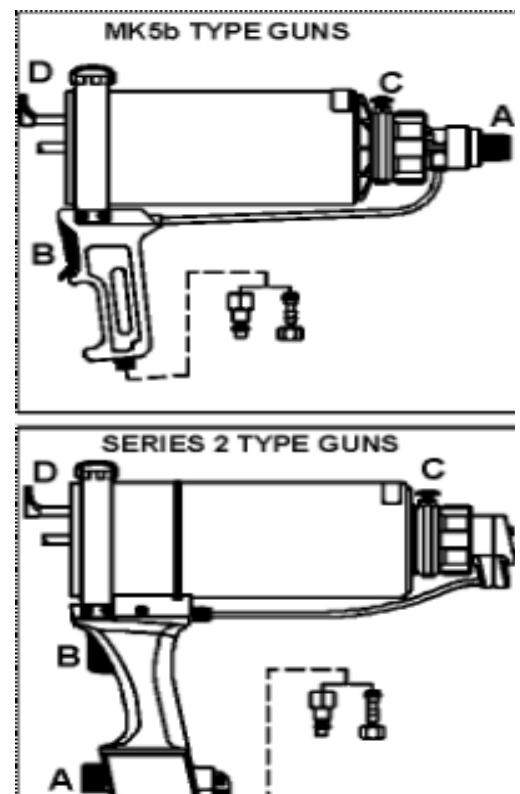

Corporate Office: 906 H.D. Atha RD – Monroe, GA 30655 - (800) 578-8555 - (770) 207-4534 - Fax (770) 207-4535

This information and technical advice provided herein are believed to be reliable and accurate to the best knowledge of Chemical Design Corp., as based on tests and should serve only as a recommendation. As the manufacturer, Chemical Design Corp. makes no representations or warranties of any kind, expressed or implied, including but not limited to all implied warranties of merchantability or fitness for use or a particular purpose for the product. Chemical Design Corp. makes no representations or warranties as to the results of the use of the product and assumes no obligation or liability in connection therewith. Chemical Design Corp. is not liable for any incidental or consequential damages of any sort from use of this product. The information provided herein is subject to change at anytime without notice. Information changes may include, but are not limited to, commercial and technical changes, changes in pricing, physical characteristics and packaging.